

1914 TILLING-STEVENS TS3

FOLLOW INSTRUCTIONS CAREFULLY
 CUT OUT PIECES IN ORDER, GENTLY SCORE
 ALONG DOTTED LINES TO EASE BENDING.
 CUT OUT ALL SPACES MARKED "CUT OUT"
 * BEND AGAINST SCORE LINES

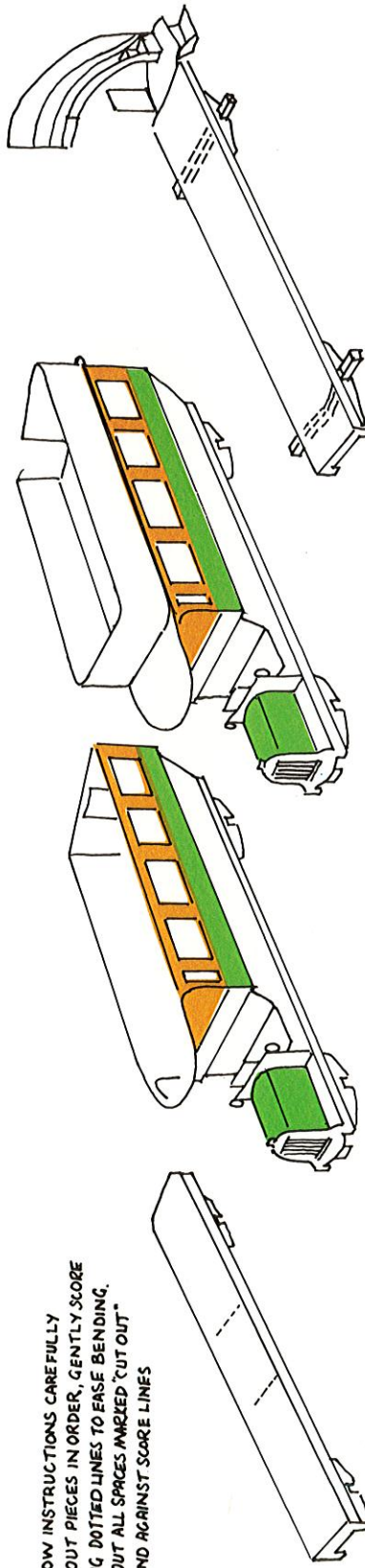

- 1 % 1 SCORE BEND GLUE TO SHAPE.
- 2 % 2 GLUE TO POSITION ON 1.
- 3 % 3 SCORE BEND TO SHAPE, GLUE TO 1.
- 4 % 4 SCORE BEND GLUE TO POSITION ON 1.
- 5 % 5 & 6 SCORE BEND TO SHAPE. AT THIS POINT GLUE ACETATE STRIPS FOR WINDOWS. GLUE TO POSITION ON 1.
- 6 % 7 & 8 SCORE BEND USE ACETATE FOR WINDOWS, GLUE TO POSITION ON 1.
- 7 % 9 SCORE BEND GLUE TO POSITION ON 1.
- 8 % 10 SCORE BEND GLUE TO INSIDE COACH.
- 9 % 11 GLUE TO POSITION ON 5 & 6.
- 10 % 12 SCORE BEND GLUE TO POSITION ON 11.
- 11 % 13 10 PIECES LEFT & RIGHT SEATING. SCORE BEND GLUE TO SHAPE. GLUE TO POSITION ON 11.
- 12 % 15 SCORE BEND GLUE TO SHAPE. GLUE TO POSITION ON PLATFORM.
- 13 % 16, 17, 18 CURVE TO FIT MODEL. GLUE TO STAIRS. % 19 BILLBOARD SHAPE GLUE TO STAIRS. % 19 BILLBOARD GLUE TO POSITION ON PLATFORM.
- 14 % 20 & 21 SCORE BEND GLUE TO SHAPE. THIS BUS IS LOCATED AT AMBERLEY CHALK PITTS.
- 15 % 22, 23, 24, 25, 26 SCORE BEND, GLUE WHEELS TO TYRES. GLUE TO FRONT. REPEAT AS FRONT WHEELS. GLUE TO REAR. % 26 SCORE BEND GLUE. GLUE TO PLATFORM FRONT & REAR MUDGUARDS. GLUE TO BUS

